

TAPE MOUNTED  
 PART NO 1218371-2 ONLY  
 SCALE 2:1

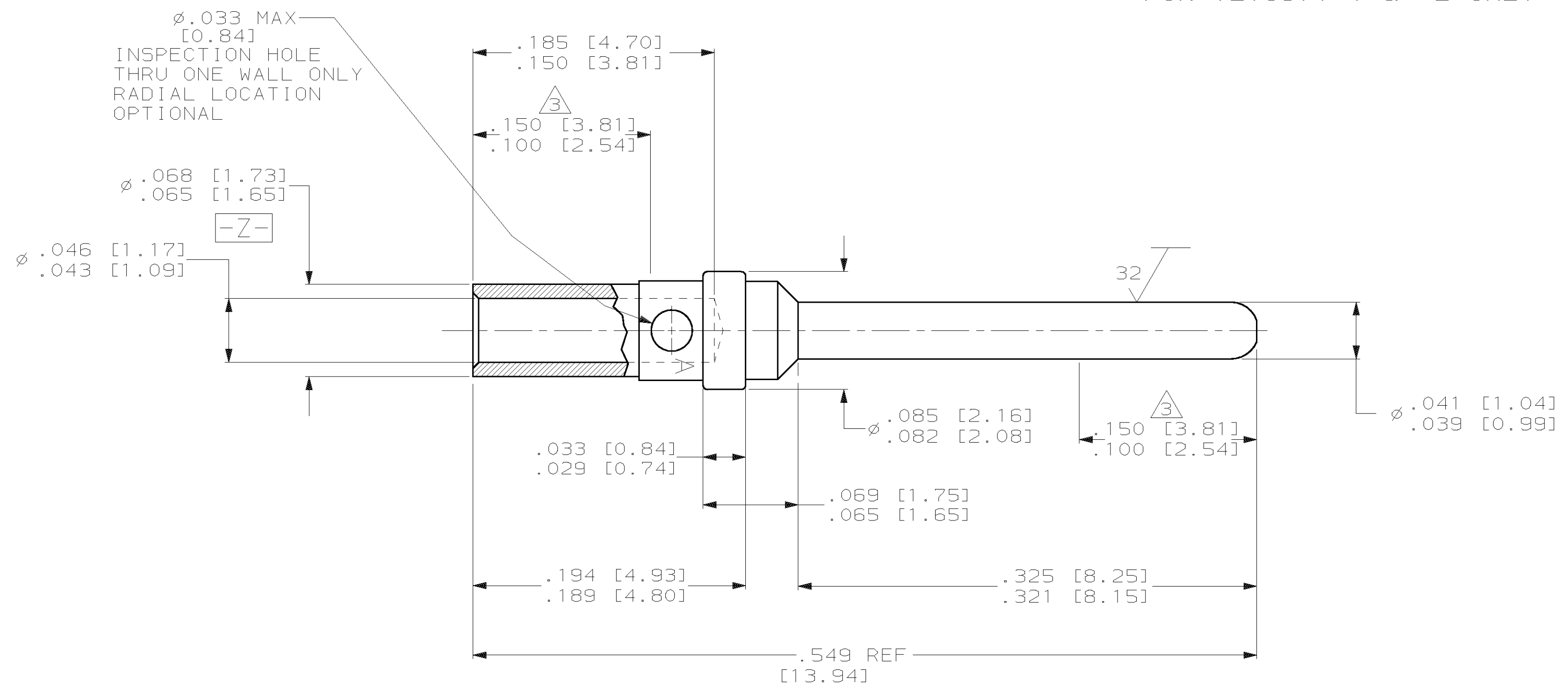
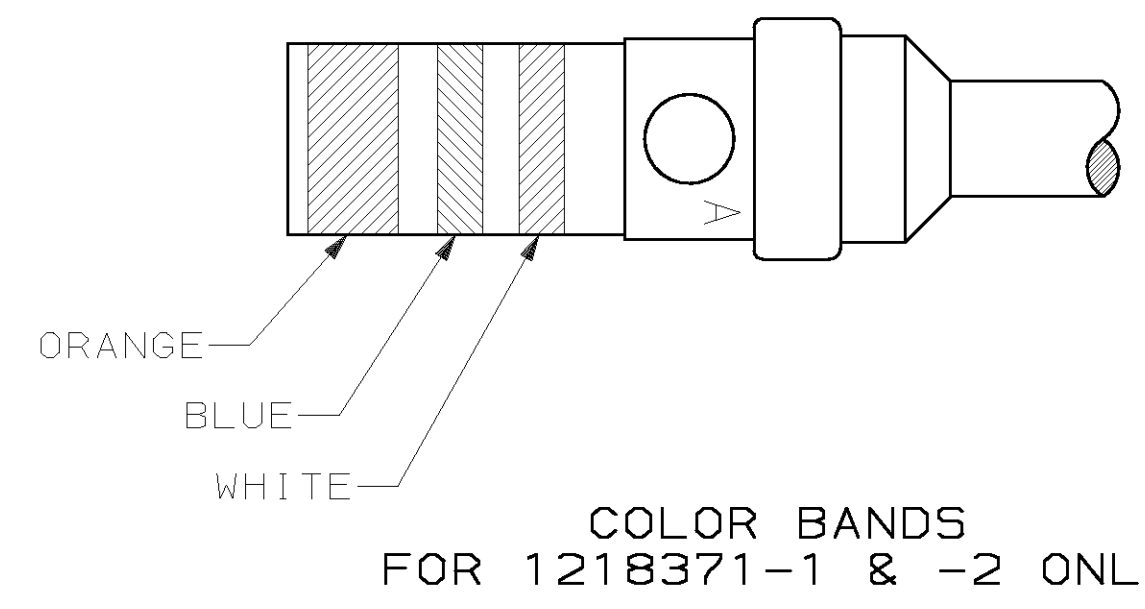

- 1 FINISH: GOLD PLATED PER MIL-G-45204, TYPE II, OVER NICKEL PER Q0-N-290.
- 2 FINISH: GOLD PLATED PER MIL-G-45204, TYPE II, OVER COPPER PER MIL-C-14550, CLASS 4.
- 3 POINT OF PLATING THICKNESS MEASUREMENT. (2 PLC)
- 4. ALL DIAMETERS  $\pm .004 Z$  UNLESS OTHERWISE SPECIFIED.
- 5. THIS PART COMPLIES WITH MIL-C-39029/64 AND M24308/11-1.
- 6. ALL SURFACES HAVE A  $63 \sqrt{\text{ }}$  OR BETTER FINISH, UNLESS OTHERWISE SPECIFIED.

WITHOUT COLOR CODE	2	1218371-3
CONTACTS ON TAPE	1	1218371-2
AS SHOWN	1	1218371-1
REMARKS	FINISH	PART NUMBER

THIS DRAWING IS A CONTROLLED DOCUMENT. DWN C.C. THOMAS 1-25-99  
 CHK R. GROSS  
 APPV R. GROSS

AMP AMP Incorporated  
 Harrisburg, PA 17105-3608

PRODUCT SPEC: #20 PIN, CRIMP, AMPLIMITE

APPLICATION SPEC: -

MATERIAL: - FINISH: - WEIGHT: -

SIZE: A1 CAGE CODE: 00779 DRAWING NO: 1218371 RESTRICTED TO: -

CUSTOMER DRAWING SCALE: 15:1 SHEET: 1 OF 1 REV: 0